

SM 80 series provide a low profile through table shock mount microphone base fitted with a flip cover to conceal the connector when closed. Available with 3-pin or 5 pin XLR connectors and with or without a Latching/PTT switch. A Mini XLR with a Phantom Power Adapter and a Latching/PTT switch is also available.



- Low profile table mounted microphone base.
- Built in shock mount to eliminate surface bound noise.
- Includes a concealed flap to allow the table to be used for other purposes.
- Requires a minimum table thickness of 25mm (1")

Additions for SM 80S and SM 80S-RF version

- Designed for remote switching.
- Bi-colour common anode LED to confirm status
- Terminated with RJ 45 connector and supplied with RJ 45 coupler which allows connection via RJ 12 or RJ 45 plug back to DSP.

SM80 Series order codes					
	Mode	Finish	3-Pin XLR	5-Pin XLR	Mini XLR
With a Switch	Latching	Black Nextel	SM 80S LATCH	SM 80SX5 LATCH	SM 80S-RF LATCH
		Satin Nickel	SM 80SN LATCH	SM 80SNX5 LATCH	SM 80SN-RF LATCH
	PTT	Black Nextel	SM 80S PTT	SM 80SX5 PTT	SM 80S-RF PTT
		Satin Nickel	SM 80SN PTT	SM 80SNX5 PTT	SM 80SN-RF PTT
Without a Switch or status LED		Black Nextel	SM 80	SM 80X5	SM 80-RF
		Satin Nickel	SM 80N	SM 80NX5	SM 80N-RF

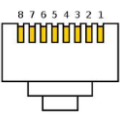
RJ45 Connector Pinout		
Cable colour	Function	RJ 45 Pin number
Red	Red LED	2
Blue	-ve switch	3
Brown	+ve 12/24V dc switch	4
Yellow	Switch Logic control	5
Green	Green LED	6

Additional Specifications for -RF versions

- Can power the C 3100, C 310R, C 313/SR, C 314/SR miniature gooseneck microphones terminated with Mini XLR 3 pin connectors.
- Contains a dedicated phantom power adaptor that accepts 9 to 48 volts DC and has impedance of 200 ohms.
- The phantom power adaptor includes filters, which eliminate all GSM frequencies from 800 - 1200 MHz
- Terminated with a male 3 pin XLR.

Wiring applicable for Clockaudio Microphones only					
Wiring for	PIN 1	PIN 2	PIN 3	PIN 4	PIN 5
3 Pin Female XLR	Ground	Phase +	Phase -		
5 Pin Female XLR	Ground	Halo -	Phase -	Halo +	Phase +
3 Pin Mini XLR	Phase -	Phase +	Ground		
3 Pin Male XLR	Ground	Phase +	Phase -		

Installation guide



Fig A



Fig B



Fig C



Fig D

- 1) Ensure minimum table thickness of 25mm (1").
- 2) Drill a 50mm (2") hole through the table (see fig A).
- 3) Remove the 3 M3 pan headed screws from the bottom plate (for SM 80 and SM 80S see fig B while for SM 80-RF see fig C).
- 4) Remove the M3 x 30 and M3 x 40 pan headed screws securing the base plate to the top assembly see fig D (note on SM 80 two M3 x 40 pan head screws used).
- 5) For SM 80S, select the LED voltage by moving the jumper to the required position see fig E.
- 6) Fit the top assembly through the 50mm (2") hole see fig F.
- 7) Re-fit the base plate to the assembly using the M3 screws adjusting the nuts to clamp the top assembly and the bottom plate to the table ensuring that the top assembly is correctly aligned before finally tightening the nuts (see fig G).
- 8) Re-fit the bottom plate to the shock mounts using the 3 M3 pan headed screws. For SM 80 and SM 80S ensure XLR is correctly aligned with the hole in the base plate (see Fig H). For SM 80-RF, adjust the height of the PPA-RF and secure with nut supplied see fig I.
- 9) Installation complete (for SM 80 and SM 80S see fig J while for SM 80S-RF see fig K).

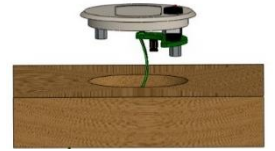

Fig F

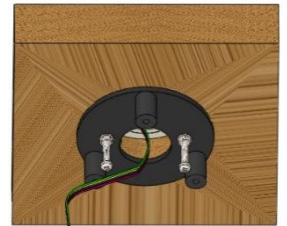

Fig G

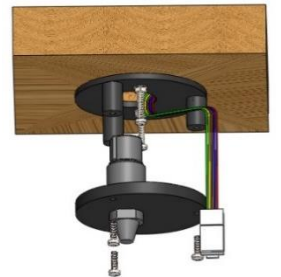

Fig H

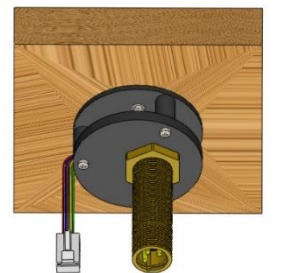

Fig I

Voltage Selector

- 24V
- 12V
- 5V

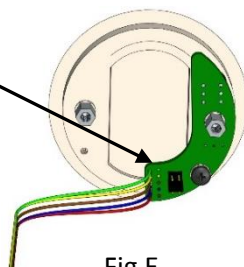

Fig E

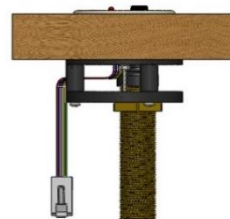

Fig K

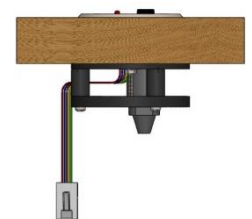

Fig J