



Installation and User Guide



CCR4000

(Motorised, Ceiling Retractable Microphone)

Thank you for purchasing a Clockaudio product. We are confident that this product will give you many years of trouble free operation.

As part of Clockaudio's continual ongoing programme of product development, improvements to the existing CCRM 4000 microphone range may be made to further increase the already excellent reliability and functionality. As such specifications / improvements are subject to change without prior notice.

This guide (latest version available from www.clockaudio.com) covers Installation and User information.

From this version of the documentation, Clockaudio is removing the terms "Master" and "Slave" and replacing them with "Main" and "Secondary" respectively.

Copyright

© Copyright 2023 Clockaudio Ltd. All rights reserved.

Disclaimer

This User Guide is written for users of the Motorised, Ceiling Retractable Microphone, to assist in installation and operation. It is not intended to be a detailed source of information.

No part of this document may be reproduced in any form without the written permission of the copyright owner.

The contents of this document are subject to revision without notice due to continued progress in methodology, design and manufacturing. Clockaudio shall have no liability for any error or damage of any kind resulting from the use of this document.

READ ME FIRST – SAFETY INSTRUCTIONS

Please ensure that the following safety instructions are followed. If the product is reissued to another party, please ensure that this document is provided.

1. Ensure that all warnings and important notes are adhered to;
2. Read and follow these instructions carefully as they contain important information concerning safety and safe operation of this equipment;
3. Heed all warnings in this manual they are there for the safety of you and others;
4. Do not install the product near heat sources such as radiators, stoves, etc...;
5. Only use the attachments supplied, specified or recommended by Clockaudio;
6. Keep these instructions in a safe place in case they need to be referred to later;
7. If the unit needs to be cleaned, only use dry cloth; the unit is not waterproof;
8. There may be a risk of fire if the unit is exposed to dripping or running water or other liquids;
9. Do not burn or incinerate the remote control battery. Danger of explosion.

Warning!

Do not remove the covers as there is sensitive equipment inside. Only Clockaudio Ltd or its approved service engineers are permitted to service this equipment. There are no user serviceable parts inside.

Caution!

Unauthorised maintenance, repair or the use of non-approved replacements may affect the equipment specification and invalidate any warranties.

Equipment covered by this User Guide.

This User Guide covers all versions of CCRM 4000 product set. The product is specifically designed for use in AV conference rooms, board rooms, court rooms, and huddle room applications or meeting room spaces.

Please note before installation.

The CCRM 4000 series motorized ceiling microphone should always be powered off between uses. If the unit is powered and inactive for extended periods of time, the unit may time out and wait only for a full power cycle before normal use is resumed. It is recommended all microphones are retracted and located within the bezels prior to powering off the system.

Please also note that powering off the unit will not affect the saved deployment height of the microphone programmed by the last user.

Contents

1	Overview	1
2	Package Contents.....	3
3	Installation	4
3.1	Single Element version of CCRM 4000.....	4
3.2	Tri Element version of CCRM 4000	8
3.3	IR Sensor Installation	11
3.4	Secondary unit wiring connections.....	11
3.5	Further Secondary wiring connection.....	12
3.6	Horizontal / Vertical mounting	13
4	Controls and Connectors	14
5	Connecting to DSP.....	16
5.1	CCRM 4000 DSP IN Connector	16
5.2	Main Unit Cable Wiring Connections using a DSP	16
5.3	DSP Mute Control	17
5.4	Audio Out Socket	18
5.4.1	Single Element version.....	18
5.4.2	Tri Element version	18
6	Programming CCRM Cable Height	19
6.1	IR Remote Control Operation	19
6.2	IR Remote Layout.....	19
6.3	IR Remote Control Additional Information.....	20
6.4	Programming Cable Height on Main Unit.....	20
6.5	Programming Cable Height on Secondary Unit	21
6.6	Programming Multiple Units.....	21
6.7	Microphone Deployment Safety Feature	21
7	Troubleshooting.....	22
8	Specifications	24
9	Product Warranty	25
10	Product Disposal	26

Page intentionally left blank

1 Overview

The CCRM 4000 product is designed for use in AV conference rooms, board rooms, court rooms, and huddle room applications or meeting room spaces. Typically mounted in the ceiling space, it allows the microphone to be released smoothly from the unit and drop down to a predefined height and when not in use to smoothly retract back into the ceiling.

Designed by Clockaudio, the CCRM 4000 fulfils its goal of a reliable motorised retractable microphone that frees up the desk space.

Major Features of CCRM 4000 includes:

- Cardioid microphones that provide an excellent front to back rejection.
- Automatic safety detection for cable hang-ups.
- Logic Hi / Lo for DSP mute detection port.
- Ceiling bezel fitted with a detection switch that allows the microphone to establish the home position.
- Single element cardioid microphone allows a 350 degree rotation of the element with 40 degree knuckle joint angle.
- Tri element cardioid microphone allows pickup of 360 degrees.
- Automatic microphone deployment via an external positive (+2.5V to +12V) signal applied to the Main's DSP port or via the IR sensor. Triggering the Main unit will also deploy any other attached Secondary units.
- Microphone output provided via a XLR socket or an RJ45 connector. If microphone was a single element version, then output will be via an XLR connector. If it was tri element then output would be an RJ45.
- Easy and fast connection of the audio from CCRM 4000 to mixer or DSP. A 9-48 Volt phantom power is required.
- Expansion capability to link/daisy chain other CCRM 4000 units. Up to 99 Secondary units can be daisy chained to a single Main unit.
- Main and Secondary units are identical in construction. Two rotary 0-9 digital decimal encoders define and set unit's address ID as well what it becomes – "00" for Main unit and "01-99" for Secondary units.
- IR remote control is supplied with the Main unit. Remote control can be used to activate the unit(s) in the absence of a DSP.
- IR receiver sensor with integral green programme mode LED and red range LED (supplied with Main unit).
- Universal mains switched mode power supply available as separate item. Operates up to 4 units.
- Audio cable length 2.5 Metres (8.2 feet).

The CCRM 4000 is available with either a single element (C3) or a tri element (C303) microphone. Both microphones, available in either black or white finish, provide an excellent pickup and proven audio quality.

Definition of whether the product appears as a Main or Secondary device is defined by the settings on the two rotary decimal encoders. If the address ID is set to 00, the unit is Main else Secondary.

It is important to note that the only difference between the Main unit and Secondary unit is that with the Main unit, the IR receiver sensor, IR remote control and the PSU are supplied. With Secondary units, these three items are not supplied.

The single element cardioid microphone is mounted on a knuckle joint that allows 350 degree rotation with up to 40 degrees bend.

The tri element capsule cardioid microphone has capsules positioned at 120 degrees apart providing a full 360 degree pickup.

For North American market, the CCRM 4000 is available with a Plenum enclosure for both the single element and tri element microphones.

Ordering options available for the CCRM 4000 are:

Type	Finish	Single Element	Tri Element
Main	Black	CCRM 4000-M-RF	CCRM 4000-M-C303-RF
	White	CCRM 4000W-M-RF	CCRM 4000-M-C303W-RF
Secondary	Black	CCRM 4000-SL-RF	CCRM 4000-SL-C303-RF
	White	CCRM 4000W-SL-RF	CCRM 4000-SL-C303W-RF
Plenum (Main)	White	CCRM 4000W-M-RF-P	CCRM 4000-M-P-C303W-RF
Plenum (Secondary)	White	CCRM 4000W-SL-RF-P	CCRM 4000-SL-P-C303W-RF

Options:

Part Number	Description
CCRM 4000-MB	Wall mounting brackets (supplied as a pair)
CCRM4000B	Wall mounting brackets for CCRM4000 – North America only
PSU-018	Power supply 18VDC 2A (Supplied with Main unit)
CCRM PSU-018	Power supply 18VDC 2A (Supplied with Main unit) – North America only
CCRM 4000-R	Remote Control for CCRM 4000
CCRM 4000-IR	Infrared sensor for CCRM 4000

2 Package Contents

The following part are supplied with each of the product types

	CCRM 4000 Type							
	Main, Single Element	Secondary, Single Element	Main, Tri Element	Secondary, Tri Element	Main, Plenum, Single Element	Secondary, Plenum, Single Element	Main, Plenum, Tri Element	Secondary, Plenum, Tri Element
CCRM 4000 unit	✓	✓	✓	✓	✓	✓	✓	✓
Single element microphone	✓	✓			✓	✓		
Tri element microphone			✓	✓			✓	✓
Audio link cable			✓	✓			✓	✓
IR receiver sensor (CCRM-4000-IR)	✓		✓		✓		✓	
IR remote control (CCRM-4000-R)	✓		✓		✓		✓	
+18 VDC universal power supply	✓		✓		✓		✓	
Safety 4 x eye bolts and wire harness	✓	✓	✓	✓	✓	✓	✓	✓
Ceiling tile fixing bracket (CCRM-4000-Rack)	✓	✓	✓	✓	✓	✓	✓	✓
Ceiling Bezel (black or white, colour dependent upon order)	✓	✓	✓	✓	✓	✓	✓	✓
Installation and User Guide	✓	✓	✓	✓	✓	✓	✓	✓
Plenum enclosure					✓	✓	✓	✓

3 Installation

This section describes the installation steps required for Single and Tri Element variants.

See Section 5.4 on connecting the audio cable to the DSP.

3.1 Single Element version of CCRM 4000

To prevent unnecessary damage to the system it's vitally important to follow the instructions below:

<p>1. The CCRM 4000 is supplied partially disassembled and requires simple push to fit reassembly. The adjacent image shows a fully assembled unit.</p>	
<p>2. Remove the CCRM 4000 system from its transportation box and remove the 2 foam end caps. The transportation box and packing should be stored as this is the best packaging to use in the unlikely event of having to return the system to your dealer.</p>	
<p>3. Cut the tape securing the large cardboard box to the large black ceiling frame.</p>	
<p>4. Carefully move the box out of the ceiling frame and set to one side being careful not to snag or cause the microphone cable to kink. Do not remove the microphone and top bezel assembly at this stage.</p>	
<p>5. Remove the small cardboard box located under the CCRM 4000. This contains the PSU (Main unit only).</p>	

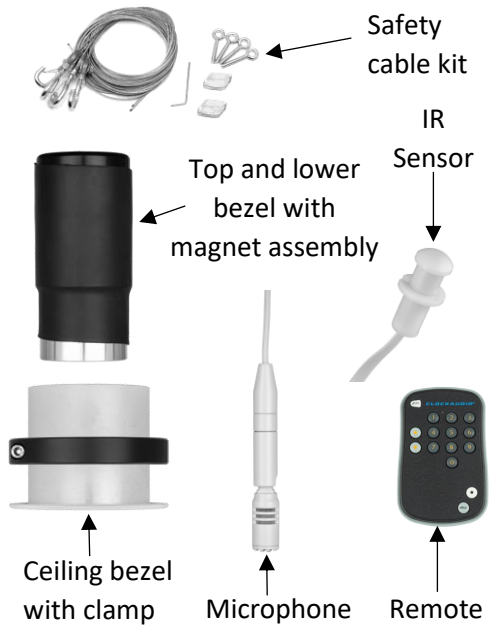
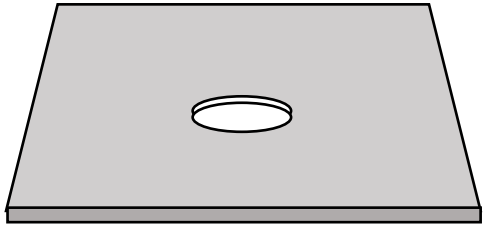
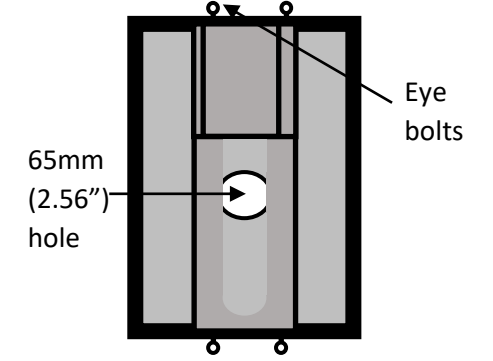
<p>6. Now open the large cardboard box and remove from the packaging the microphone and large ceiling bezel with bezel clamp.</p>	 <p>Safety cable kit</p> <p>Top and lower bezel with magnet assembly</p> <p>IR Sensor</p> <p>Ceiling bezel with clamp</p> <p>Microphone</p> <p>Remote</p>
<p>7. To install this system, cut a 65 mm (2.56") hole into the ceiling tile to allow the large ceiling bezel, just removed from the packaging, to be fixed to the tile. The hole should ideally be cut in the centre of the tile and must not be closer than 76mm (3") from the edge of the tile or it will not be possible to align the CCRM 4000 support bracket over the hole.</p>	
<p>8. Take the entire CCRM 4000 kit up to the final location site. Carefully align the CCRM 4000 complete with ceiling tile bracket so that the large slot is directly over the hole that has previously been cut in the ceiling for the bezel.</p> <p>Ensure that the front and back of the bracket fits snugly over the ceiling tile "T-Bar rails". Secure the ceiling bracket to the T Bar rails using the supplied four eye bolts finger tight.</p>	 <p>Eye bolts</p> <p>65mm (2.56") hole</p>
<p>9. Insert the ceiling bezel up through the ceiling tile through the hole and slot in the tile bracket. Secure the bezel in place with the bezel clamp using a 5mm Allen key.</p>	
<p>10. Now carefully remove from the foam packing the IR sensor, remote control and safety cable fixing kits and set aside.</p> <p>Next remove the top bezel containing the magnet assembly and Mini XLR microphone connector.</p>	

11. Insert the microphone through the lower ceiling bezel and then push fit the top part of the bezel to the lower bezel making sure the magnet is inside the top part of the bezel.

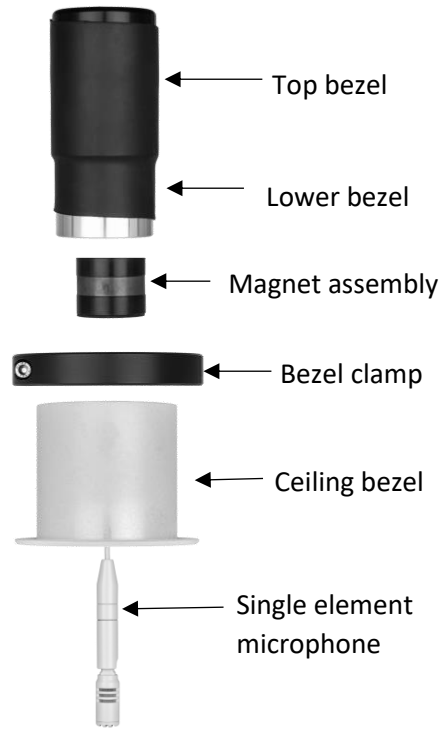

12. Remove any kinks or bends in the cable by gripping the cable with your hands and pass it through a clean dry cloth a few times. This will straighten the cable. Connect the RJ12 plug from the top bezel into Socket 2 (BEZEL) on the Main unit.



13. For safety reasons the frame to ceiling tile fixing eye bolt (2 at each end of the bracket) are used to secure the frame and also used to suspend the CCRM 4000 and bracket. Unravel the Y cable harnesses and attach the hooks to the eye bolts at each end of the ceiling tile bracket.

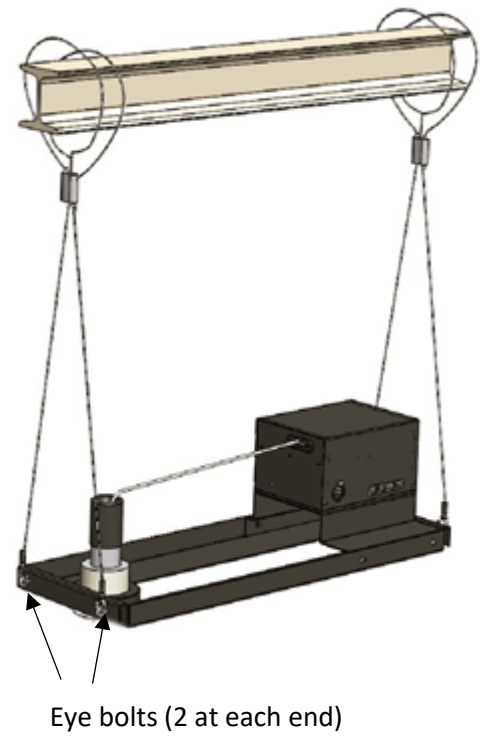

14. Push the free end of the cable harness through one of the holes located on the Gripper. Now loop the free end of the cable over a secure fixing such as a ceiling truss, eye bolt, or any structure capable of taking 7Kgs of weight. Now pass the cable through the remaining hole in the Gripper and then pull on the cable to adjust / take up the slack. Do the same with the other Y cable at the other end of the ceiling tile bracket.

Cable can be slackened or removed by inserting the supplied release key into the hole as shown.

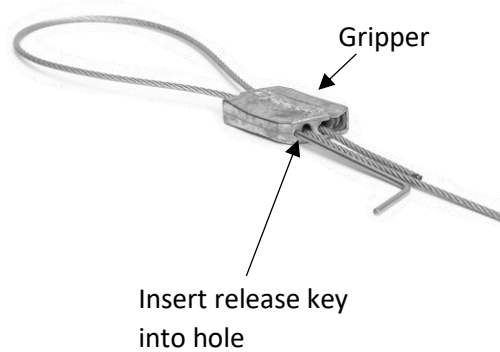

15. Knuckle Joint adjustment:

After installation has been completed it is important to operate the unit a few times to allow the cable to settle and find its natural final rest position. The microphone can then be aligned correctly and the knuckle joint angle positioned for best audio reception.

Important: The microphone angle is limited to 40 degrees from vertical as shown.

NOTE: If the cable hits an obstruction such as a desk / floor or is held preventing the upward motion (0.5lbs pull) of the cable motor will immediately stop. Remove the obstruction and then press the up button on the remote, or up command if using a DSP. The unit can now be operated normally. Should this fail to restore normal operation disconnect and reconnect the supply Voltage to the CCRM 4000.

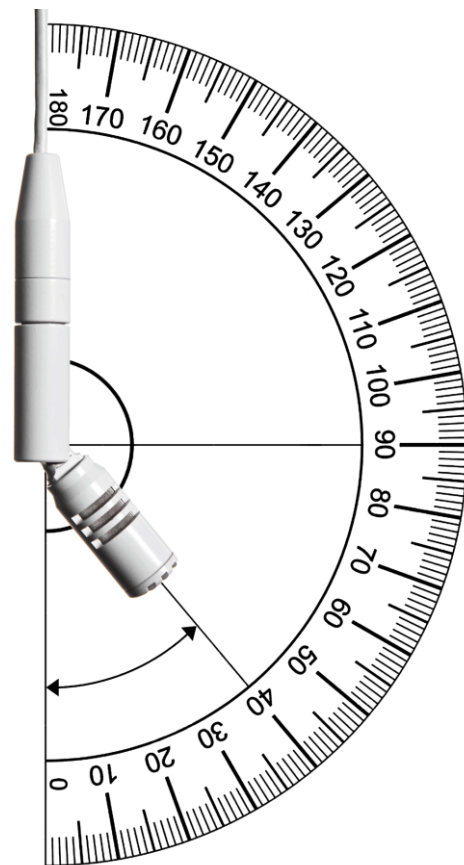

3.2 Tri Element version of CCRM 4000

To prevent unnecessary damage to the system it's vitally important to follow the instructions below:

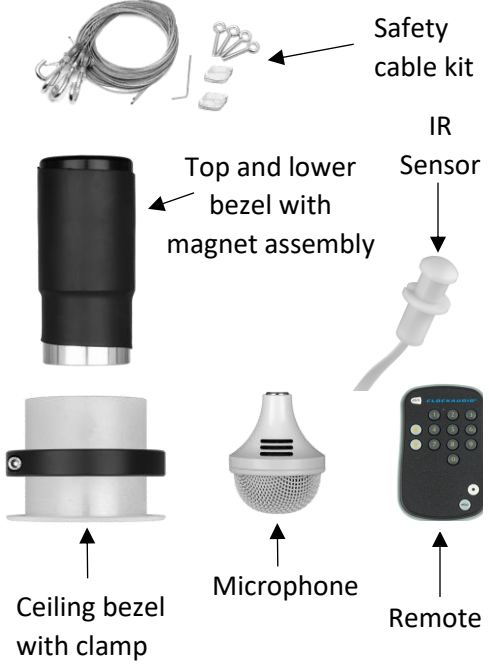
<p>1. The CCRM 4000 is supplied partially disassembled and requires simple push to fit reassembly. The adjacent image shows a fully assembled unit.</p>	
<p>2. Remove the CCRM 4000 system from its transportation box and remove the 2 foam end caps. The transportation box and packing should be stored as this is the best packaging to use in the unlikely event of having to return the system to your dealer.</p>	
<p>3. Cut the tape securing the large cardboard box to the large black ceiling frame.</p>	
<p>4. Remove the small cardboard box located under the CCRM 4000. This contains the PSU (Main unit only).</p>	
<p>5. Now open the large cardboard box and remove from the packaging the microphone and large ceiling bezel with bezel clamp.</p>	

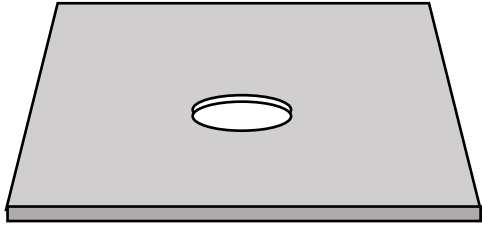
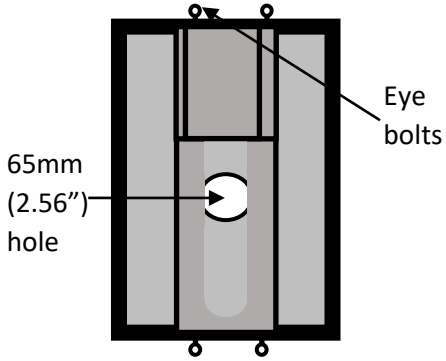
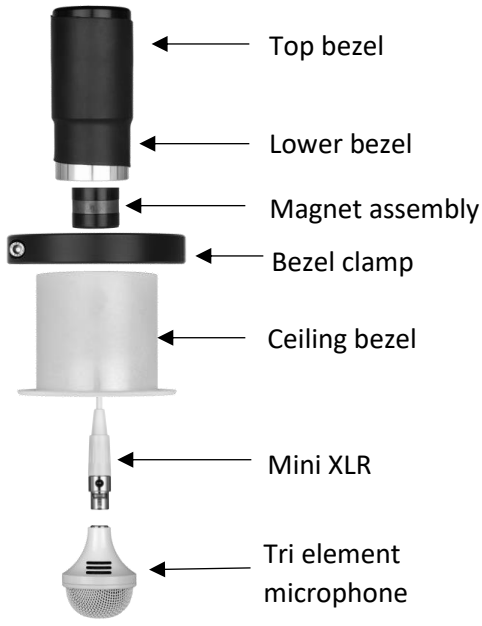
<p>6. To install this system, cut a 65 mm (2.56") hole into the ceiling tile to allow the large ceiling bezel, just removed from the packaging, to be fixed to the tile. The hole should ideally be cut in the centre of the tile and must not be closer than 76mm (3") from the edge of the tile or it will not be possible to align the CCRM 4000 support bracket over the hole.</p>	
<p>7. Take the entire CCRM 4000 kit up to the final location site. Carefully align the CCRM 4000 complete with ceiling tile bracket so that the large slot is directly over the hole that has previously been cut in the ceiling for the bezel.</p> <p>Ensure that the front and back of the bracket fits snugly over the ceiling tile "T-Bar rails". Secure the ceiling bracket to the T Bar rails using the supplied four eye bolts finger tight.</p>	
<p>8. Insert the ceiling bezel up through the ceiling tile through the hole and slot in the tile bracket. Secure the bezel in place with the bezel clamp using a 5mm Allen key.</p>	
<p>9. Now carefully remove from the foam packing the IR sensor, remote control and safety cable fixing kits and set aside.</p> <p>Next remove the top bezel containing the magnet assembly and Mini XLR microphone connector.</p>	
<p>10. Carefully feed the Mini XLR microphone connector through the lower bezel and push fit the top part of the bezel over the lower bezel, making sure the magnet assembly is inside the top part of the bezel.</p>	

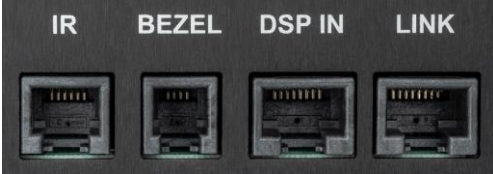
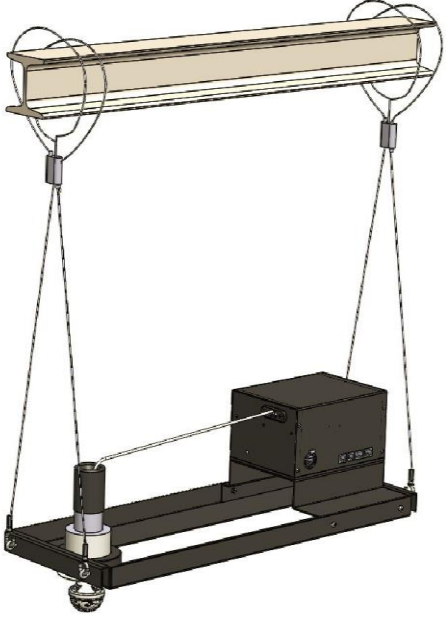
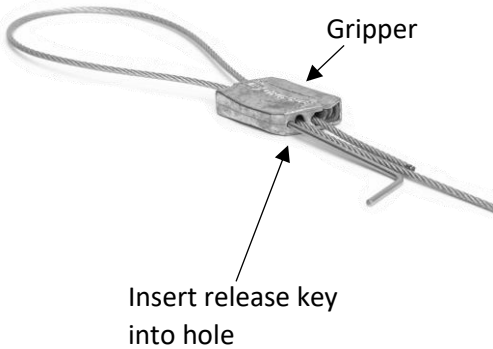
<p>11. Connect the microphone on to the Mini XLR connector (push fit).</p> <p>WARNING: Do not operate the CCRM 4000 without connecting the microphone.</p>	
<p>12. Remove any kinks or bends in the cable by gripping the cable with your hands and pass it through a clean dry cloth a few times. This will straighten the cable. Connect the RJ12 plug from the top bezel into Socket 2 (BEZEL) on the Main unit.</p>	
<p>13. For safety reasons the frame to ceiling tile fixing eye bolt (2 at each end of the bracket) are used to secure the frame and also used to suspend the CCRM 4000 and bracket. Unravel the Y cable harnesses and attach the hooks to the eye bolts at each end of the ceiling tile bracket.</p>	
<p>14. Push the free end of the cable harness through one of the holes located on the Gripper. Now loop the free end of the cable over a secure fixing such as a ceiling truss, eye bolt, or any structure capable of taking 7Kgs of weight. Now pass the cable through the remaining hole in the Gripper and then pull on the cable to adjust / take up the slack. Do the same with the other Y cable at the other end of the ceiling tile bracket.</p> <p>Cable can be slackened or removed by inserting the supplied release key into the hole as shown.</p>	

3.3 IR Sensor Installation



Mount the IR sensor in a position (ceiling or wall) where it will be convenient to see all the CCRM 4000 movements whilst maintaining good line of site with the IR sensor. Do not place any obstruction in front of the sensor as this will prevent operation.

Drill a 16mm (5/8") diameter hole. Pass the sensor through the hole and secure it using the C clip. Connect the cable to the IR sensor input Socket 1 (IR) on the CCRM 4000 unit.

IR sensor has 2 coloured LED's: Green illumination while in programme mode and Red during normal operation. The LEDs will illuminate each time a button is pressed on the remote.

3.4 Secondary unit wiring connections

When adding a second CCRM 4000 unit as a Secondary device

<p>1. Connect a DC supply cable between the Main and Secondary DC input sockets. Make sure that the correct polarity is applied to the Phoenix plug supplied.</p> <p>Use a minimum AWG 18 wire gauge to connect DC power between CCRM 4000 units. Try and keep the cable as short as possible.</p>	
<p>2. Make sure that the "Units" rotary decimal encoder is set to other than "0" e.g. "1" (01).</p>	
<p>3. Connect Socket 4 (LINK) on the Main unit to Socket 3 (DSP IN) on the Secondary unit using an RJ45 straight through cable.</p>	
<p>4. Connect the Bezel cable to Socket 2 (BEZEL)</p>	
<p>5. Connect the appropriate cable to the DSP – XLR for the single element and CAT5 cable for the tri element.</p>	

Main / Secondary CCRM 4000 Connectivity Diagram

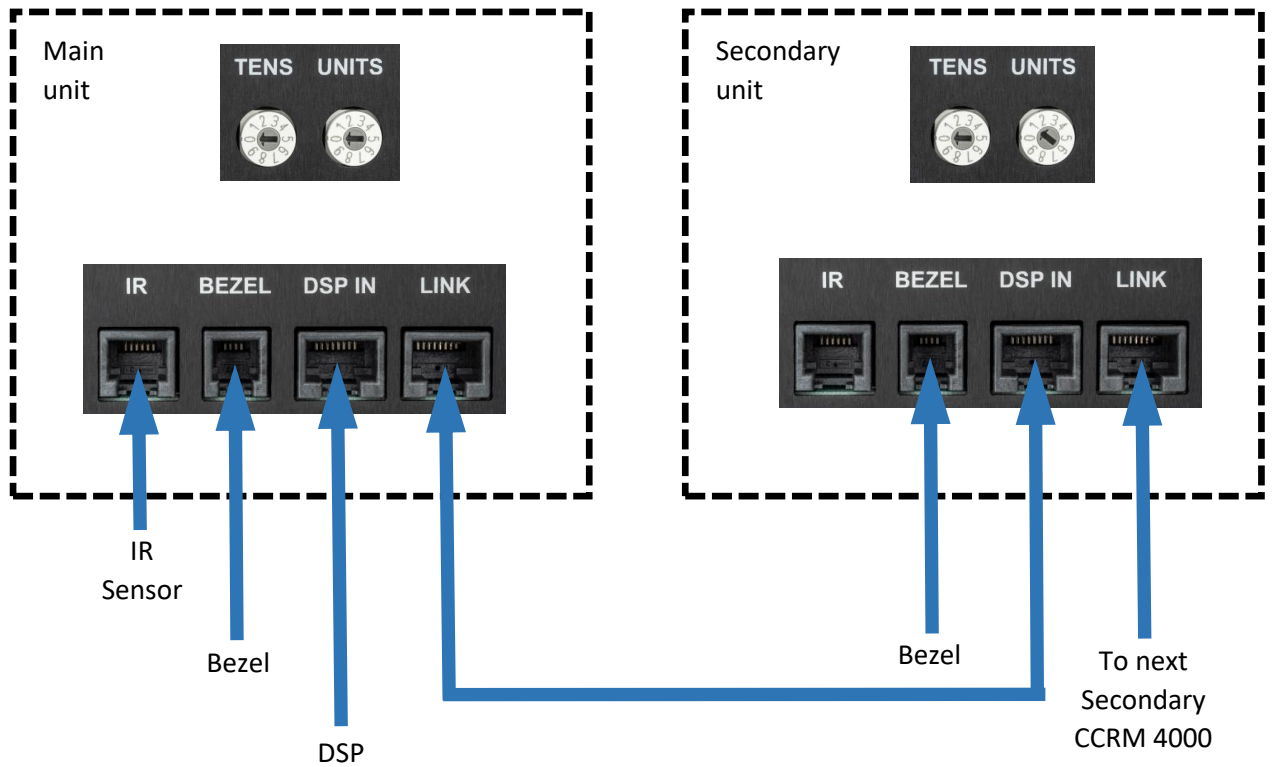

3.5 Further Secondary wiring connection

For addition of further Secondary units, connect a CAT5 between Socket 4 (LINK) and Socket 3 (DSP IN) of the next Secondary. Repeat for additional units to form a daisy chain. Ensure that each additional CCRM 4000 unit is set with a unique address using the rotary decimal encoder e.g. "2" for second, "3" for third, etc...

Up to 99 Secondary units can be linked together in the same / identical way.

3.6 Horizontal / Vertical mounting

Apart from mounting the CCRM 4000 units in the ceiling space, these units can also be mounted on a wall or a bracket attached to the ceiling. In either case a secure bezel attachment, where the microphone emanates from, will need to be addressed by the installer.

Caution: When mounting horizontally on a wall or vertically on a ceiling or a support, ensure that the correct type of fasteners are used to support the CCRM 4000. As each type of install is different, fasteners are not supplied.

Horizontal mounting:

Using a pair of metal brackets (fixed using 6 x M4 x 12 countersunk screws), attach the CCRM 4000 to the wall. Mount the bezel appropriately where required.

Remember that the further away the unit is mounted from the microphone and bezel, less cable will be available for the cable drop (cable length is 2.5 Metres max (8ft 2in.)).

Wall fixing metal brackets are available as optional extra.

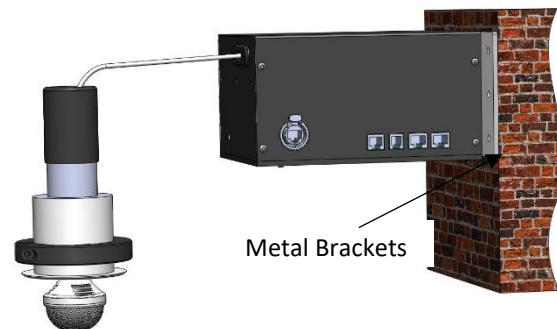

Vertical mounting:

Using a pair of metal brackets (fixed using 6 x M4 x 12 countersunk screws), attach the CCRM 4000 to the ceiling. Mount the bezel appropriately where required.

Remember that the further away the unit is mounted from the microphone and bezel, less cable will be available for the cable drop (cable length is 2.5 Metres max (8ft 2in.)).

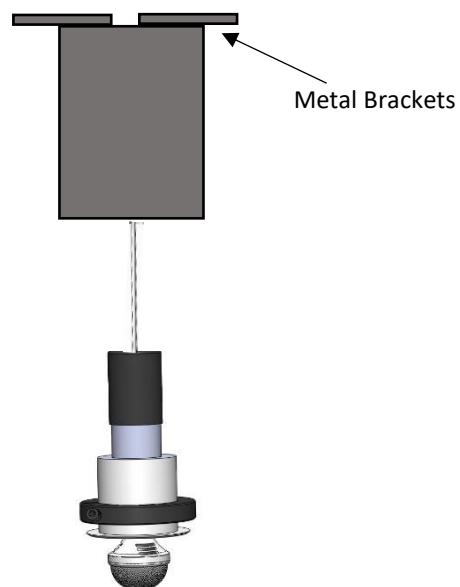

Wall fixing brackets are available as an optional extra.



4 Controls and Connectors

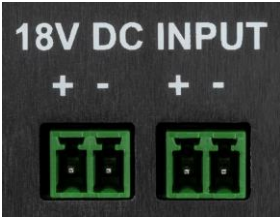

On both sides of the CCRM 4000 there are controls and connectors.

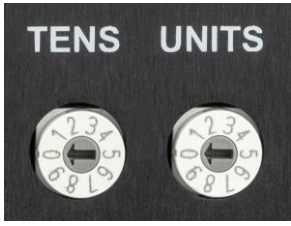

Description	Connector
<p>Power</p> <p>Two +18VDC power connectors are provided. One can be used for power In, while the other can be used to distribute power to the next daisy chained unit.</p> <p>Using Clockaudio recommended PSU, up to 4 CCRM 4000s can be daisy-chained.</p>	 <p>The image shows two green 18V DC INPUT connectors. Each connector has a '+' and '-' terminal. The text '18V DC INPUT' is printed above the connectors.</p>
<p>Impedance matching "Z"</p> <p>On each of the units is a slide switch "Z". In a multi-unit system of 2 or more units, it is only the final Secondary unit that needs to have this switch ON and all other units' switches must be OFF.</p>	 <p>The image shows a slide switch labeled 'Z' with 'ON-OFF' markings. To the left is a green connector with '+' and '-' terminals. To the right is a rotary switch labeled 'TEN' with numbers 1, 2, 3, 4, 5, 6, 7, 8, 9, 0.</p>

<p>Unit selector ID – Two rotary decimal encoders provide the unit’s address ID number.</p> <p>By default the unit’s ID number is on the CCRM 4000 is set “00”.</p> <p>Secondary units need to be setup with a number that is non-zero. All Secondary units MUST have unique ID numbers.</p>	
--	--

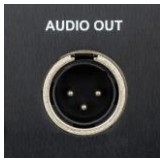
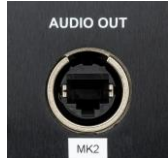
On the other side of the CCRM 4000, there are additional connectors

Description	Connector
<p>Single element CCRM 4000 provides audio out via a single 3 pin XLR connector</p>	
<p>Tri-Element CCRM 4000R provides audio out via a single RJ45 connector.</p>	
<p>IR (Socket 1)</p> <p>Connects to the IR sensor. This sensor (supplied with Main units only) is used to initially program the height of each microphone.</p>	
<p>BEZEL (Socket 2)</p> <p>This RJ12 connector is connected to the Bezel and senses the home position for the microphone.</p> <p>IMPORTANT: Do not plug the RJ12 connector into any other socket else this could result in damaging the internal pins of the other sockets.</p>	
<p>DSP IN (Socket 3)</p> <p>Connects to the DSP. Receives trigger from the DSP to deploy the microphones and provides status indicating mic is in deployed position.</p>	
<p>LINK (Socket 4)</p> <p>Provides trigger for the Secondary CCRM 4000, receives mic deployment status of Secondary and for inter-device communication.</p>	

5 Connecting to DSP

5.1 CCRM 4000 DSP IN Connector

The table below lists the pin functions for DSP control signals to the Main unit. Secondary units require just a daisy cable link (standard straight RJ45 male to male cable required) between Main and Secondary units. Check that the DSP control signal is present; logic +2.5 to 12 Volts is required.

The logic control signal (pin 1) is an optically isolated input with a dedicated return connection (pin 2). Voltages as low as 2.5V DC are recognised as a 'logic high' which will command the Main unit (and any connected Secondary units) to deploy their microphones to a pre-set height. A 'logic low' (0V DC) will command all units to raise their microphones to the ceiling.

Socket 3 (DSP IN) Pin No.	Description
1	Logic Control Signal Input: Between +2.5V DC and +12V DC: Microphones down to set-height. 0V: Microphones up to ceiling bezel switch.
2	GND Return for Logic Control Signal. Note: This is not a common GND for the unit, it is the return leg of an optically isolated input.
3	Mute Feedback Signal. Open collector output that requires a pull-up resistor (10K Ohm) at the DSP to function correctly. 0V: Microphones not deployed (Mute) High Impedance (Pulled-Up to voltage): Microphone deployed (Un-Mute)
4	GND Return for Mute Feedback Signal. Note: This is not a common GND for the unit, it is the return leg of an optically isolated output.
5	RS485 (+) Communications (Inter-device communication)
6	RS485 (-) Communications (Inter-device communication)
7	RS485 0V (Not used on Main unit)
8	Unused

5.2 Main Unit Cable Wiring Connections using a DSP

Connect Socket 3 (DSP IN) to the DSP. Ensure that all parameters are met in accordance to the instructions shown under "Mute Control" and Logic Hi /Lo 2.5V – 12V required for activation is available. This cable provides muting info to DSP and receives trigger to deploy CCRM 4000.

Connect the microphone audio output to DSP audio input. Phantom power must be supplied to the microphone. For tri element CCRM 4000 use the link cable. DSP is used to mute the microphone.

5.3 DSP Mute Control

Each CCRM 4000 provides its mute status via Socket 3's optically isolated open-collector output. The Secondary units cascade their status into the Main's Socket 4. This collective mute signal is presented to the DSP which is then responsible for the actual muting.

The drawing below represents an equivalent circuit for the mute signal which shows how the open collector output on each CCRM 4000 is connected in parallel when the units are connected together using the correct RJ45 connection cable.

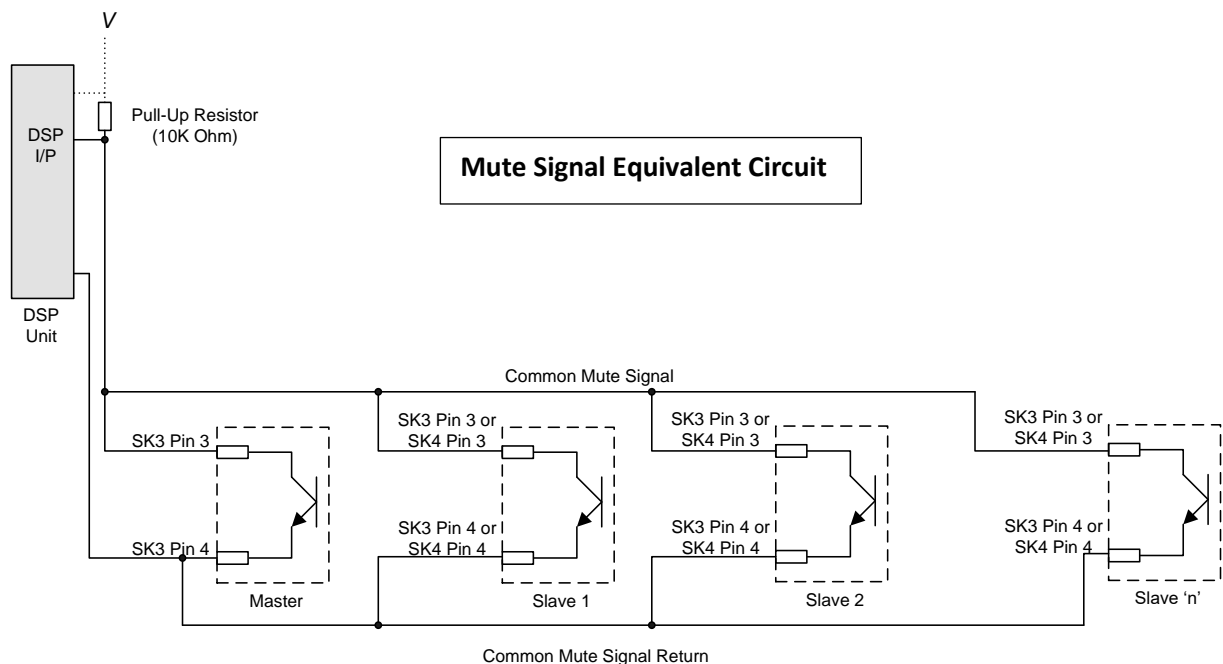

To function correctly, the common mute signal from all units must be connected via an external pull-up resistor (not supplied) to an arbitrary voltage (V) at the DSP as illustrated above. The arbitrary pull-up voltage (e.g. 5V DC or 12V DC) can either be supplied by the DSP itself (preferred option), or by an external voltage source, although if an external voltage source is used, the 0V return must be common with the DSP 0V.

When the microphones are not deployed, the voltage on the common mute signal will be pulled to the common signal return (logic low at the DSP input). The DSP input will only switch to the logic high state when all microphones are deployed and resting at the pre-set height.

Note that the common mute signal must be provided with an external voltage through a 10K Ohm pull-up resistor, the mute signal will not function without this.

5.4 Audio Out Socket

The type of socket on the Audio out is dependent upon the type of CCRM 4000 that was purchased.

5.4.1 Single Element version

On the single element CCRM 4000 audio output is provided via a 3 pin XLR connector for connection to a mixer or DSP. Phantom power adaptor is inbuilt but requires an external 9-48VDC phantom power to be applied.

5.4.2 Tri Element version

On the tri element CCRM 4000, audio output is provided via a RJ45 Socket for connection to a mixer or DSP. Phantom power adaptor is inbuilt but requires an external 9-48VDC phantom power to be applied.

Supplied with the tri element CCRM 4000 is a link cable to enable fast connection of the audio output to the preferred audio device (DSP / Mixer). Connect a CAT 5 cable with a RJ45 male plug at each end (not supplied) to the RJ45 Socket on the link cable. Connect the 3 x Phoenix connectors of the link cable to the preferred audio device (mixer / DSP).

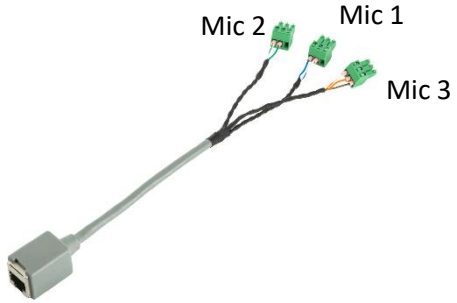
Audio Out RJ45 Socket			
RJ45 Pin no.	Cable Colour	Function	
1	Orange/White	Mic 3 Phase +	
2	Orange	Mic 3 Phase -	
3	Green/White	Mic 2 Phase +	
4	Blue	Mic 1 Phase +	
5	Blue/White	Mic 1 Phase -	
6	Green	Mic 2 Phase -	
7	Brown/White	Not used	
8	Brown	Ground	

6 Programming CCRM Cable Height

6.1 IR Remote Control Operation

The remote is primarily intended to allow the initial programming of the desired height for each individual CCRM 4000 in the system. The preferred operation is then by logic input from a DSP logic high of 2.5V to 12V to trigger release of the microphone to the programmed height; logic 0 low will raise the microphone. The IR remote Up/Down buttons can be used if a DSP is not used.

NOTE: In some countries, the battery for the remote is shipped separately and may need to be inserted into the remote. If battery is shipped inside the remote, then open the battery compartment pull and remove the battery insulator / protector.

Warning: Deployment or retraction of the microphones is done with either the IR Remote or the DSP. It will not work if deployed using IR remote and retracted via DSP or vice versa.

6.2 IR Remote Layout

The following table describes the functions of the IR Remote Control

Function	Description	
Aux	Used to programme the remote.	
Up	Used to rewind cable upwards.	
Down	Used to deploy cable downwards.	
Enter	Used to complete / store a programme.	
Setup	Only used to programme the remote.	
Numeric buttons	Used to input Main / Secondary designation and programme remote.	

The red LED indicator shows with each press of any button. If the LED fails to light then replace the battery.

Replacement battery type: Lithium 3V CR2025

WARNING: DANGER OF EXPLOSION DO NOT BURN OR INCINERATE THE BATTERY.

Remote code 0515

When the battery is replaced it may be necessary to re-code the remote. Press Aux, Press and hold Setup until red led lights, enter 0515 on the key pad. Remote coding is now set.



6.3 IR Remote Control Additional Information

- When programming an incorrect address ID code, for example 32, and that address ID does not exist, it will just be ignored / nothing will happen when either the up-arrow or down-arrow keys are pressed. Wait 5 seconds and re-enter the correct address code.
- While initially programming the cable height, the Up and Down buttons work on a press and hold basis. The microphone will continue to move either up or down all the time the button is pressed. The cable will stop when either button is released.
- If there is a pause of longer than 5 seconds between button presses before the ENTER button is pressed, the sequence will need to be restarted from the beginning. Once the green programme LED is lit there is no time-out limit.
- A green LED will be lit on the IR sensor to indicate that programme mode has been entered. The LED will extinguish upon exiting the programme mode (press Enter). Thereafter each time a remote button is pressed a red LED will flash indicating the transmitter is in range and a command has been received.
- IR range is approximately 7.5M (25 feet).
- Deployment of the microphone can be done using either the IR Remote or the DSP. However, whatever method is used to deploy the microphone, the same method must be used to retract it. For instance, trying to retract a microphone using the IR Remote if it had been deployed via a DSP will not work. Same case if the microphone was deployed using the IR remote, it cannot be retracted using the DSP. Only use one method to deploy or retract.

6.4 Programming Cable Height on Main Unit

The remote control is used to set up the cable height and can also be used to deploy and retract the microphone. For a single unit installation (Main) the default factory setting is set to 00.



- Point the remote at the IR receiver and press 00 followed by the ENTER button (green LED will light on the IR sensor showing it's in programme mode). Press the Up / Down buttons on the remote. Set the correct height of the microphone. Press the ENTER button to store this height position into the memory (green LED will go out). Immediately afterwards the microphone will retract to the ceiling bezel to confirm that the operation has been successful.
- Test by briefly pressing the Down button on the remote and the microphone will move down and stop at the programmed height. Press the Up button and the microphone will retract back up to the Bezel. If an incorrect height has been programmed then repeat the above instructions.

6.5 Programming Cable Height on Secondary Unit

Make sure that a non-zero number has been selected on the Secondary unit e.g. 01.

Note: Additional Secondary units must have unique numbers



Point the remote at the IR Sensor press the ID number of the Secondary unit (e.g. 01) followed by the ENTER button (Green programme LED on the IR sensor will light). Press the Up / Down buttons on the remote to set the correct height of the microphone. Press the ENTER button to store the desired height in the memory (Green LED will extinguish).

Immediately afterwards the microphone will retract to the ceiling bezel to confirm that the operation has been successful.

Briefly press the Down button and the microphone. This will trigger the microphone to drop down and stop at the programmed height. Press the up button and the microphone will retract back up to the Bezel. If an incorrect height has been programmed then repeat the above instructions

6.6 Programming Multiple Units

As each additional Secondary unit is added it will be necessary on each of the Secondary to change the “units” decimal rotary address switch to “2” for the 2nd Secondary / “3” on the 3rd Secondary etc.... Then as described above repeat the button sequences on the remote to set each of the cable heights on each of the Secondary units in turn. Don’t forget to enter the Secondary unit’s assigned number on the remote (02 or 03, 04, etc.) before completing the programming sequence. If 10 or more CCRM 4000s are being used then it will be necessary to change the Tens rotary address on the 10th Secondary to “1” and Units rotary switch to “0” (10), for the 11th Secondary select “11” and so on. Once programming is complete, verify that all microphones are deployed simultaneously by pressing the down button.

6.7 Microphone Deployment Safety Feature

If the cable hits an obstruction such as a desk / floor or is held preventing the upward motion 0.22Kg pull (0.5lbs pull) of the cable motor, the unit will immediately stop. Remove the obstruction and then press the up or down button on the remote, or up or down command if using a DSP to retract or deploy the microphone. The unit can now be operated normally. Should this fail to restore normal operation disconnect and reconnect the supply Voltage to the CCRM 4000.

7 Troubleshooting

The following table describes some of the common faults and how to rectify them

<p>1. Microphone does not move up or down</p>	<ul style="list-style-type: none"> • Check that the DSP control signal is present. Logic +2.5 to 12 Volts is required. • Remove and reapply the DSP control signal. • Check DC supply is present (microphone will move down and up when power is applied). • Check logic input cable connections between DSP and DSP input port • Perform a reset by switching the dc supply off / on. • All units within a daisy-chained system must perform a home position calibration prior to resuming normal operation following a power interruption. Remove and reapply the DSP control +2.5V to 12 Volts to redeploy all microphones.
<p>2. Microphone is picking up noise as it is being raised / lowered.</p>	<ul style="list-style-type: none"> • This is normal. The microphone must be muted by the DSP during the raising / lowering transitions.
<p>3. Remote control not operating</p>	<ul style="list-style-type: none"> • Check if a battery is installed or the battery insulator has been removed. • Check that there is clear view of transmitter to IR sensor. The red LED on the IR sensor should light each time a button is pressed. • Check remote red LED is showing when buttons are pressed. Check or replace the remote battery. • Check IR sensor is connected to the Socket 1 (IR) on the Main unit. • Check that the correct address code (if adjusting height) for the CCRM 4000 has been input.

Cautions

1. Never grab hold of or stop the cable whilst the cable is being deployed. This may cause jamming of the mechanism of the cable.
2. Do Not Exceed the Maximum carrying weight of 0.5lbs on the microphone cable. This will cause the internal safety device to engage and stop the unit operating.
3. Do not add / extend the cable length. There is insufficient space to accommodate any extra cable length.
4. Do not operate the mechanism in any other angle / position than specified.

IMPORTANT DO NOT ATTEMPT ANY DISSASSEMBLY OF OTHER PARTS WITHOUT PRIOR WRITTEN PERMISSION FROM CLOCKAUDIO.

8 Specifications

	Single Element CCRM 4000	Tri Element CCRM 4000
Polar pattern (each capsule)	Cardioid (120 degrees coverage)	Cardioid (360 degrees coverage with all three capsules activated)
Frequency response	50Hz – 18KHz	
Sensitivity	-40dB +/-3dB at 1KHz (0dB=1 V/Pa)	-37dB @ 1KHz (0dB 1v/Pa)
Impedance	200 Ohms	
S/N Ratio	64dB (A)	69dBA
Max SPL	125dB @ 1KHz 1%THD	
Power Requirements	Main unit: Voltage 18 VDC 0.5A Microphone capsule: 9-48V phantom power	
Connectors	<ul style="list-style-type: none"> • 2 x 18VDC Power • 1 x RJ45 IR Sensor • 1 x RJ12 Bezel • 1 X RJ45 DSP IN • 1 x RJ45 LINK • 1 x 3 pin XLR for Audio Out 	<ul style="list-style-type: none"> • 2 x 18VDC Power • 1 x RJ45 IR Sensor • 1 x RJ12 Bezel • 1 X RJ45 DSP IN • 1 x RJ45 LINK • 1 x RJ45 for Audio Out • Link cable is supplied with female RJ45 fan out to 3 x Phoenix connectors
Dimensions without ceiling tile bracket	190mm (6.69") L x 140mm (5.51") W x 104mm (4.09") H	
Dimensions with ceiling tile bracket	620mm (24.5") L x 215mm (8.5") W x 180mm (7") H	
Dimensions with packaging	680mm (26.77") L x 290mm (11.42") W x 250mm (9.84") H	
Cable length	2.5 Metres (8.2ft)	
Safety Harness (each)	Capable of holding 10Kg	
Weight	2.7Kg (5.95 lb) without ceiling tile bracket 6.8Kgs (13.22 lb) with ceiling tile bracket 7.6Kg Gross (max)	
Operating Temperature	0 to 40 degC	
Storage Temperature	-20 to 60 degC	
Relative Humidity	10 to 90% non-condensing	

9 Product Warranty

This product is offered with a 1 year warranty from the date of purchase. Any defect that arises due to faulty materials or workmanship will either be replaced, or repaired free of charge by the agent from whom you purchased the unit. Please note charges will be incurred on any products returned for service / repair not in warranty or have been subject to customer abuse or incorrect wiring.

The warranty is subject to the following provisions:

- The warranty does not cover accidental damage, misuse, cabinet parts, knobs, batteries or consumable items. Any product returned to Clockaudio failing to meet the terms listed will incur a repair and carriage charge.
- The product must be correctly installed and operated in accordance with the instructions supplied with the product.
- Unauthorised modifications and alterations to the original specifications will render the warranty void.
- The product must be used for the sole purpose that it was designed for.
- The warranty given is strictly with the original owner and becomes invalid if the product is resold or becomes damaged by inexpert repair.
- Product purchased outside of the countries served by Clockaudio designated / approved agents are not covered by the warranty.
- Specifications / improvements are subject to change without notice.
- Clockaudio disclaims any liability for incidental or consequential damages.
- The warranty is in addition to and does not diminish your statutory legal rights.

CLOCKAUDIO IS NOT RESPONSIBLE FOR INCIDENTAL OR CONSEQUENTIAL DAMAGES INCLUDING LABOUR COSTS FOR REMOVING AND REPLACING DEFECTIVE PRODUCTS OR PARTS. THIS DOES NOT AFFECT YOUR STATUTORY RIGHTS.

10 Product Disposal

At the end of the life of this equipment, dispose of equipment according to local regulations



For more information and advice on Clockaudio products please visit the Clockaudio website:
www.clockaudio.com

Corporate Headquarters: Clockaudio Limited,
Wellington Gate,
Silverthorne Way,
Waterlooville,
Hampshire, PO7 7XY,
United Kingdom

Tel: +44 23 92251193

Subsidiaries:	Clockaudio North America Inc.	Clockaudio Pte. Ltd
	2891 Rue du Meunier, Unit 103, Vaudreuil Dorion, Quebec, J7V 8P2, Canada	BizTech Centre, Unit #01-02, 627A Aljunied Road, Singapore 389842
	Tel: + 1 450 4249797	Tel: +65 67484738
	Fax: + 1 450 4243660	Fax: +65 67484428

